

**Specifications**

File:	Equipment Manual – Section 070
Replaces:	070.500-SPC (SEP 2012)
Dist:	10
Revised:	October 19, 2022

## Rotary Screw Compressors

### TDSH 163 to 283, TDXB/TDXH 355 to 408

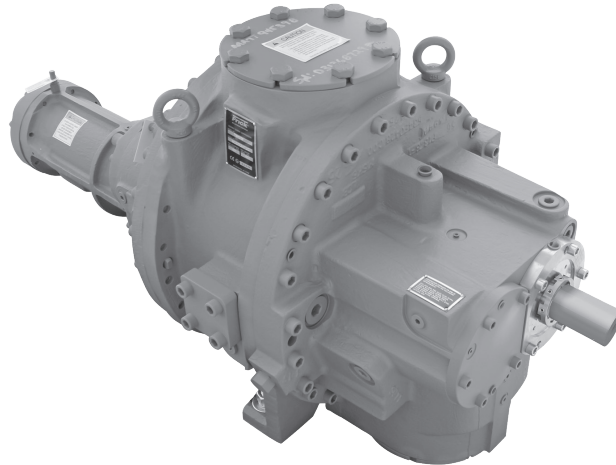

### Features and benefits

Frick® TDS\_ / TDX\_ screw compressors are designed to compress a variety of gases in many different applications including refrigeration, air conditioning, water chilling, wellhead compression, gas gathering, and vapor recovery. Applications include booster duty (low temperature/pressure), high (single) stage, or swing duty compression.

The TDSH compressor is used in typical refrigeration and natural gas applications where pressure retaining housings of cast iron are allowed. The TDXB/H compressors are used in applications requiring pressure retaining housings such as gas processing or refrigeration in chemical or petrochemical applications. Specifics of the housing materials are discussed under Materials of Construction on page 2.

**Stepless Capacity Control** - A hydraulically or manually actuated slide valve moves axially along the rotor mesh line to provide unloading. See charts on following pages for percentages. Unloaded gas is bypassed back to suction before compression has begun, allowing the compressor to efficiently accommodate system requirements.

**Variable Volume Ratio** - A hydraulically actuated slide stop adjusts slide valve length to optimize internal discharge pressure. This matches compressor volume ratio to system pressure ratio and eliminates the power penalties associated with under- or overcompression.

**Antifriction Bearings** - Cylindrical roller bearings handle radial loads, and angular contact ball bearings, aided by

balance pistons, absorb thrust loads. No preloading is required. Depending on design conditions, with correct lubrication and maintenance, bearing life can be in excess of 100,000 hours. Roller bearings also maintain superior rotor positioning to minimize internal leakage and provide excellent performance. System differential pressure is normally sufficient as the driving force to supply oil to the bearings, thereby eliminating the need for an oil pump. Antifriction bearings have lower frictional horsepower requirements for lower power consumption. Compressor housings are machined to provide static oil reservoirs for the bearings.

**Oil Injection** - Injected oil lubricates the bearings, balance piston, and seal, fill any leakage paths between and around the rotors to prevent gas bypassing, and maintain superior efficiencies. Oil injection minimizes noise and vibration. It keeps the compressor cool to prevent overheating by absorbing much of the heat from compression.

**Dynamically Balanced** - Rotors and rotating parts are dynamically balanced to demanding requirements providing low vibration from high speed rotation.

**Quality Engineered** - Designed and built to meet the exacting requirements of the Industrial Refrigeration Market. Expert engineering, automated machining centers, clean temperature controlled assembly, and stringent quality control requirements, all contribute to ensuring easy installation, reliable operation, and convenient servicing.

## Materials of construction

**Standard screw compressor casings for 163 through 283** sizes are close grain, pressure tight, grey cast iron Class 40 per ASTM A48 with material certificate type 3.1. This ensures structural integrity and mechanical and thermal stability under application operating conditions.

**Alternate casing materials for 163 through 283 sizes** Ductile iron grade 60-40-18 per ASTM A395 and ASME SA 395 including a Charpy V-notch test at room temperature and a material certificate type 3.1 per EN 10204. Material is similar to European standard EN 1563, material designation EN-GJS-400-18.

Steel casting per ASTM A352 grade LCB, LC2, LC3 is also available.

**Standard screw compressor casings for 355 and 408** sizes are ASTM A352 grade LCB, LC2, LC3 cast steel to ensure structural integrity and mechanical and thermal stability under application operating conditions.

**Flanges** - Suction and discharge flanges comply with ANSI B16.5. A 150 class suction is standard on 163-283 sizes. A 300 class suction flange is standard on the 355 and 408, and is optional on all other models. A 300 class discharge flange is standard on all models. The 408S model has 400 class as standard.

**Rotors** - Made from the highest quality carbon steel to exacting tolerances of the latest Frick rotor profile design. The 163 through 233 rotors are machined from hot-rolled bar stock. The 283, 355, and 408 rotors are forgings. Rotors are dynamically balanced to class Q2.5 (ISO 1040).

**Rotor Dampers** - TDXB/TDXH compressors have rotor dampers to inhibit vibration, providing smooth operation.

**Bearings** - Rolling elements and rings are AISI 52100 medium carbon alloy steel. Cages are brass, polyamide, or steel. Tolerance quality complies with ABEC 1 through 3.

**Slide Valve Spindle** - Low carbon steel.

**Slide Valve Indicator Rod** - Stainless steel.

**Slide Stop Indicator Rod** - Stainless steel.

**Pistons, Spacers, Etc.** - Gray cast iron, steel plate, regular carbon steel plate, or various types of hot rolled, cold rolled or cold drawn steel bar.

**Retaining (Snap) Rings & Spring Washers** - High carbon spring steel.

**Bolts** - Grade 8.8, heat treated, medium carbon steel, socket head cap screws.

**Static Seals** - HNBR O-rings. Viton® also available.

**Dynamic Seals** - Carbon filled teflon.

**Shaft Seal** - Spring-loaded stationary carbon end face rides in a stainless steel carrier against a rotating nonmagnetic cast iron alloy (Ni-resist) floating seat. The assembly is vented to low pressure to extend seal life. Secondary seals are HNBR or Viton® O-rings. Alternate seal designs and materials are available for some applications.

TYPICAL PERFORMANCE													
Model		R-290 (Propane)				R-717 (Ammonia / NH <sub>3</sub> )				Natural Gas (SG=.65, k=1.26)			
		Capacity		Power		Capacity		Power		Capacity		Power	
		TR	kW	BHP	kW	TR	kW	BHP	kW	MMSCFD	MSCMH	BHP	kW
TDSH	163S	108.7	382	120	89	126	443	146	109	0.362	0.427	29.6	22
	163L	136.9	481	151	113	159	559	184	137	0.456	0.538	37.0	28
	193S	183.7	646	198	148	213	749	235	175	0.656	0.774	46.0	34
	193L	244.9	861	264	191	284	999	314	234	0.874	1.031	61.0	45
	233S	326.1	1147	346	258	384	1,351	410	306	1.129	1.332	81.4	61
	233L	410.6	1444	435	325	483	1,699	517	386	1.422	1.678	102.5	76
	233XL	507.3	1784	538	401	598	2,103	638	476	1.757	2.073	126.7	94
	283S	584.3	2055	620	462	688	2,420	736	549	2.044	2.412	147.0	110
	283L	735.8	2588	780	582	866	3,046	926	691	2.574	3.037	185.1	138
	283SX	885.3	3113	939	700	1,044	3,673	1,117	833	3.097	3.654	222.7	166
TDXB/H	355S	905.7	3185	999	745	1,066	3,748	1,169	872	3.146	3.712	222.9	166
	355L	1235.1	4344	1,362	1,016	1,453	5,111	1,594	1,189	4.290	5.062	303.9	227
	355XL	1572	5528	1,882	1,403	1,850	6,505	2,032	1,515	5.460	6.442	386.8	288
TDXB	355U	1985.7	6983	2,377	1,773	N/A	N/A	N/A	N/A	6.897	8.138	490.2	366
TDXH	408S	1527.3	5371	1,715	1,279	1,792	6,302	2,006	1,495	5.481	6.467	383.0	286
	408L	2114.7	7437	2,375	1,771	2,482	8,729	2,777	2,070	7.589	8.954	530.3	395
	408XL	2502.4	8801	3,052	2,276	2,937	10,329	3,286	2,450	8.980	10.595	627.5	468

**Notes:**

- Abbreviations: SG=Specific Gravity, k=Ratio of Specific Heats (Cp/Cv), TR=Tons Refrigeration, kW=Kilowatts, BHP=Brake Horsepower, MMSCFD=Million Standard Cubic Feet per Day, MSCMH=Thousand Standard Cubic Meters per Hour.
- R-290 ratings based on 20°F (-6.7°C) suction and 95°F (35°C) condensing with 10°F (5.5°C) liquid subcooling and 10°F (5.5°C) suction superheat at 3550 RPM.
- R-717 ratings based on 20°F (-6.7°C) suction and 95°F (35°C) condensing with 10°F (5.5°C) liquid subcooling and 10°F (5.5°C) suction superheat at 3550 RPM.
- Natural gas ratings based on 25 PSIA (172 kPa), 80°F (27°C) suction and 75 PSIA (517 kPa) discharge at 1800 RPM.

## Design limitations and mechanical characteristics

This information is intended to be used in conjunction with CoolWare™ to establish that an application is within the operating envelope for the compressor. Consult Johnson Controls for the latest CoolWare™ version.

	TDSH COMPRESSOR MODELS									
	163S	163L	193S	193L	233S	233L	233XL	283S	283L	283SX
Approx. Compr. Weight lb (kg)	1,220 (555)	1,280 (580)	1,720 (780)	1,895 (860)	2,670 (1,210)	2,950 (1,340)	3,300 (1,500)	4,100 (1,860)	4,400 (2,000)	4,700 (2,136)
Rotor Dia. mm	163		193		233			283		
Drive Arrangement	Directly driven by the male rotor in the clockwise direction as viewed from the driver									
Minimum Driver Speed <sup>(1)(2)</sup> RPM	600 <sup>(1)(2)</sup>									
Maximum Driver Speed RPM	4,500							3,600 (For higher RPM, contact factory)		
Max. Input Power to Rotor Shaft bhp (kW)	250 (186) <sup>(1)</sup>		450 (336) <sup>(1)</sup>		750 (559) <sup>(1)</sup>			1,400 (1044) <sup>(1)</sup>		
Min. Breakaway Torque ft-lb (Nm)	7 (9.5)		10 (13.5)		14 (19.0)			20 (27.1)		
Mass Moment of Inertia <sup>(3)</sup> ft <sup>2</sup> -lb <sub>m</sub> (m <sup>2</sup> -kg)	2.2 (.093) <sup>(3)</sup>	2.7 (.11) <sup>(3)</sup>	5.1 (.21) <sup>(3)</sup>	6.5 (.27) <sup>(3)</sup>	13 (.55) <sup>(3)</sup>	16 (.67) <sup>(3)</sup>	18 (.77) <sup>(3)</sup>	33 (1.4) <sup>(3)</sup>	41 (1.7) <sup>(3)</sup>	48 (2.0) <sup>(3)</sup>
Suction Flange in. (mm)	4 (102)		5 (127)	6 (152)		8 (203)	10 (254)			
Discharge Flange in. (mm)	3 (76)		4 (102)		6 (152)			8 (203)		
Theoretical Displacement ft <sup>3</sup> /rev. (m <sup>3</sup> /rev.)	.10069 (.002851)	.12679 (.003590)	.16653 (.004716)	.22204 (.006240)	.29301 (.008297)	.36897 (.01045)	.45580 (.01291)	.52501 (.01487)	.66113 (.01872)	.79546 (.02253)
Displ. at 3550 rpm Driver Speed ft <sup>3</sup> /min (m <sup>3</sup> /hr)	357 (607)	450 (765)	591 (1,004)	788 (1,339)	1,040 (1,767)	1,310 (2,225)	1,618 (2,749)	1,864 (3,167)	2,347 (3,988)	2,824 (4,798)
Displ. at 2950 rpm Driver Speed ft <sup>3</sup> /min (m <sup>3</sup> /hr)	297 (505)	374 (636)	491 (835)	655 (1,113)	864 (1,468)	1,088 (1,849)	1,345 (2,284)	1,549 (2,631)	1,950 (3,314)	2,347 (3,987)
Displ. at 1750 rpm Driver Speed ft <sup>3</sup> /min (m <sup>3</sup> /hr)	176 (299)	222 (377)	291 (495)	389 (660)	513 (871)	646 (1,097)	798 (1,355)	919 (1,561)	1,157 (1,966)	1,392 (2,365)
Displ. at 1450 rpm Driver Speed ft <sup>3</sup> /min (m <sup>3</sup> /hr)	146 (248)	184 (312)	242 (410)	322 (547)	425 (722)	535 (909)	661 (1,123)	761 (1,293)	959 (1,629)	1,153 (1,960)
Capacity Control	Infinitely adjustable from 100% to approx. 10% (23% - 233XL, 15% - 283S/L, 26% - 283SX) by piston- or handwheel-actuated slide valve									
Volume Ratio	Infinitely adjustable from 5.0 to 2.2 (283SX - 4.15 to 2.2) <sup>(7)</sup>									
Max. Inlet Press. psia (bara) <sup>(1)</sup>	150.0 (10.3) <sup>(1)</sup>									
Max. Outlet Press. psia (bara) <sup>(1)(5)(6)</sup>	414.7 <sup>(1)(5)</sup> (28.6) or 614.7 <sup>(6)</sup> (42.4)									
Minimum Inlet Temp. <sup>(4)</sup> °F (°C) <sup>(1)</sup>	-76.0 (-60.0) <sup>(1)</sup>									
Maximum Inlet Temp. °F (°C) <sup>(1)</sup>	200.0 (93.3) <sup>(1)</sup>									
Maximum Outlet Temp. °F (°C) <sup>(1)</sup>	300.0 (148.9) <sup>(1)</sup>									
Maximum Temp. Dif. (Suct. to Disch.) °F (°C) <sup>(1)</sup>	250.0 (121.1) <sup>(1)</sup>									
Max. Bearing Oil Supply Temp. °F (°C) <sup>(1)</sup>	230.0 (110.0) <sup>(1)</sup>									

### Notes:

- Contingent upon compression ratio, bearing L<sub>10</sub> limitations, oil viscosity, and other operating conditions.
- Compressor suction flow may be zero at full unload slide valve position below 1800 RPM.
- Does not include coupling. Resolved to drive shaft.
- At compressor suction flange. Minimum evaporator temperature can be lower.
- Standard close grain, pressure tight, grey cast iron housings.
- Ductile iron ASTM A395 grade 60-40-18, or cast steel A352 grade LCB, LC2, LC3; 614.7 psia (42.4 bara).
- Available with a 1.7 - 3.0 volume ratio.

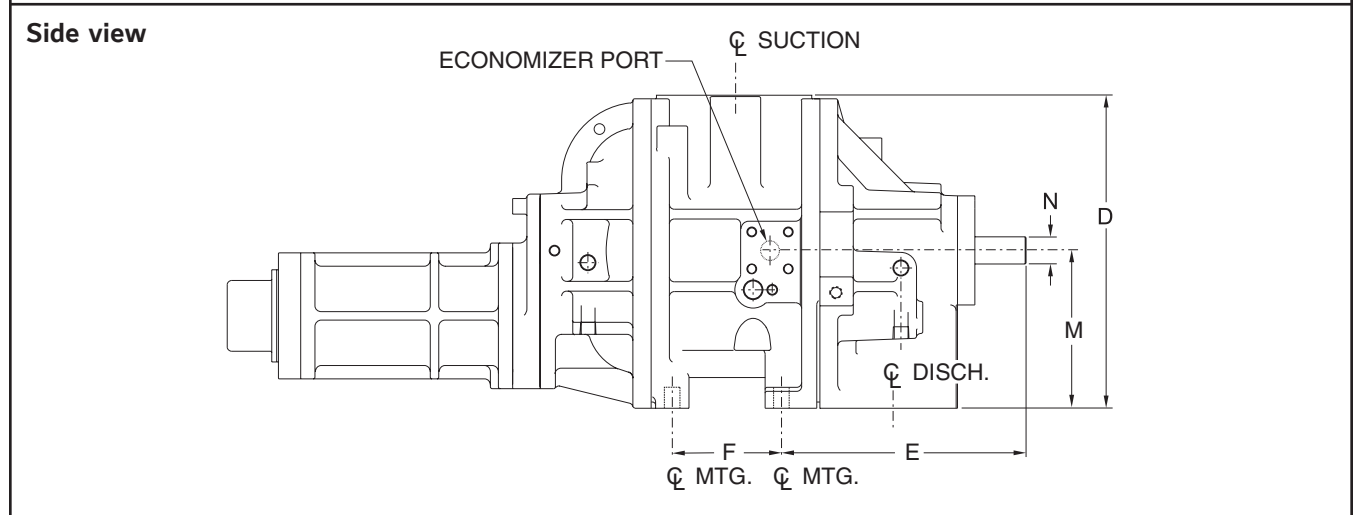
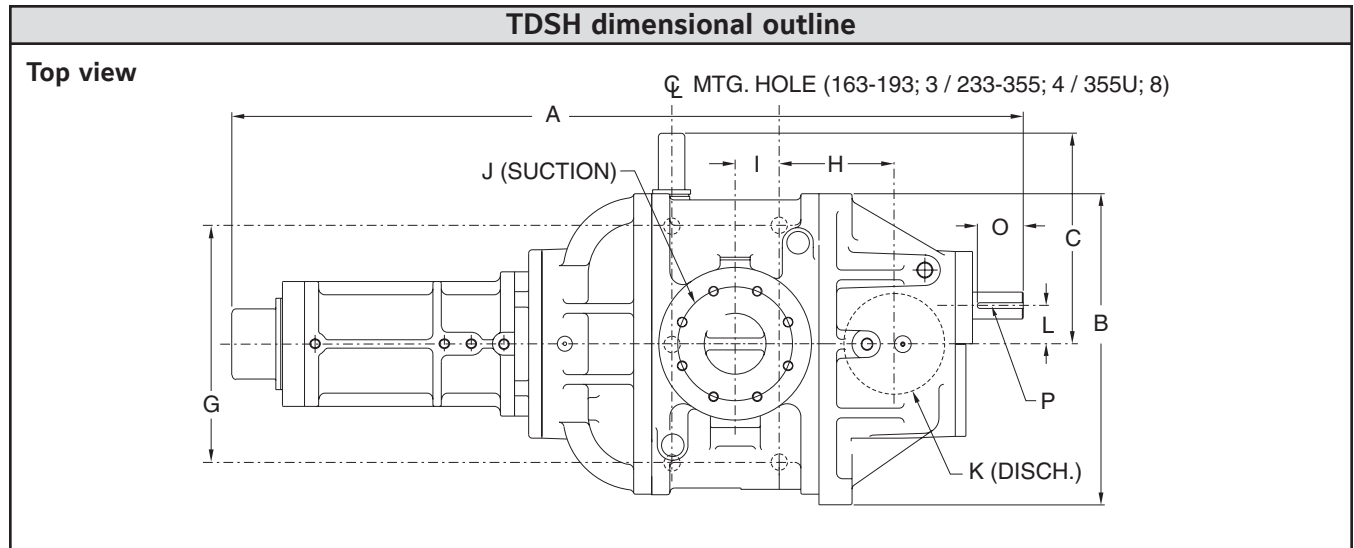

Approximate dimensions	TDSH compressor models									
	163S	163L	193S	193L	233S	233L	233XL	283S	283L	283SX
A in. (mm)	49.60 (1260)	51.85 (1317)	58.23 (1479)	61.65 (1566)	66.52 (1690)	69.72 (1771)	74.36 (1889)	71.95 (1828)	75.85 (1927)	80.31 (2039)
B in. (mm)	20.39 (518)		22.76 (578)		25.00 (635)			29.50 (749)		
C in. (mm)	13.81 (351)		14.75 (375)		16.13 (410)		16.25 (413)	18.43 (468)		
D in. (mm)	21.46 (545)	20.32 (516)	24.02 (610)	22.68 (576)	26.72 (679)	25.63 (651)	26.72 (679)	28.75 (730)		
E in. (mm)	15.87 (403)		18.82 (478)		20.97 (533)			18.30 (465)		
F in. (mm)	4.84 (123)	7.09 (180)	6.10 (155)	9.52 (242)	6.52 (166)	9.72 (247)	13.4 (340)	22.84 (580)	26.74 (679)	31.19 (792)
G in. (mm)	14.96 (380)		16.54 (420)		20.12 (511)			22.24 (565)		
H in. (mm)	7.44 (189)		8.19 (208)		9.58 (243)			5.12 (130)		
I in. (mm)	1.89 (48)	2.99 (76)	2.44 (62)	4.17 (106)	3.26 (83)	4.86 (123)	6.70 (170)	24.21 (615)	28.11 (714)	32.56 (827)
J in. (mm)	4.00 (102)		5.00 (127)	6.00 (152)		8.00 (203)		10.00 (254)		
K in. (mm)	3.00 (76)		4.00 (102)		6.00 (152)			8.00 (203)		
L in. (mm)	2.52 (64)		2.98 (76)		3.60 (91)			4.37 (111)		
M in. (mm)	10.24 (260)		11.42 (290)		12.88 (327)			15.25 (387)		
N in. (mm)	1.75 (44)		2.25 (57)		2.50 (64)			3.25 (83)		
O in. (mm)	3.00 (76)		3.75 (95)		3.81 (97)			5.00 (127)		
P in. (mm)	0.38 (10)		0.50 (13)		0.63 (16)			0.88 (22)		

**Notes:**

1. A TDSH 163 is shown for illustrative purposes only. Configurations of other compressor sizes vary slightly.
2. The economizer port in model 233-355 compressors is located on the outlet housing.
3. The suction flange on model 283 and 355 compressors is located on the inlet housing.

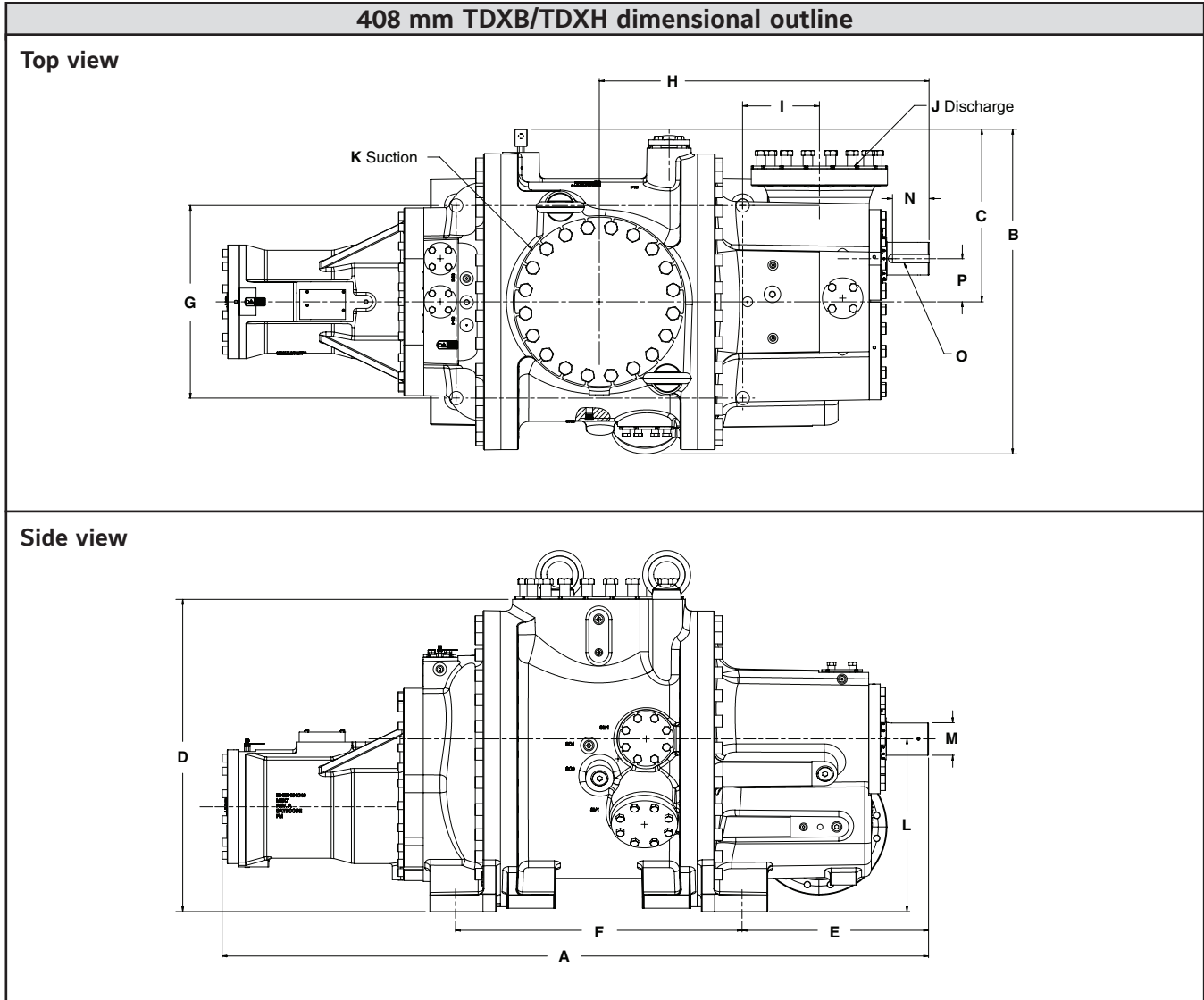

**Notes:**

1. A TDXH 408L (side discharge arrangement) is shown for illustrative purposes only. Configurations of other compressor sizes vary slightly.
2. See page 6 for corresponding 408S, 408L, 408XL dimension information.

TDS_ series model number explanation	
<b>Example: TDSH 283L</b>	
<b>TD S H</b>	<b>283 L</b>
<b>Model/series</b>	<b>Rotor length designation</b>
TDSH	S - 1.3
<i>(No additional meaning is assigned to these characters for models in the 163 - 283 rotor diameter range.)</i>	L - 1.7 / 1.8 <small>(L/D = Length ÷ Diameter)</small>
	XL - 2.1 / 2.4
	SX - 2.1
	<b>Rotor diameter</b>
	163 - 163 mm
	193 - 193 mm
	233 - 233 mm
	283 - 283 mm

TDX_ series model number explanation	
<b>Example: TDXH 355S</b>	
<b>TD X H</b>	<b>355 S</b>
<b>Housing material</b>	<b>Rotor length designation</b>
TD - Cast Steel	S - 1.1 / 1.3
<b>Rotor blocking diameter configuration</b>	L - 1.5 / 1.8 <small>(L/D = Length ÷ Diameter)</small>
	XL - 1.9 / 2.1
X - Squeeze film damper	<b>Rotor diameter</b>
<b>Axial bearing type (mm)</b>	355 - 355 mm
	408 - 408 mm
B - 4-Point (QJ) ball bearings	
H - Angular contact ball bearings	

**October 2022 revisions**

- Throughout - Updated Frick and Johnson Controls logos
- Page 1 - Updated bearing life duration phrasing in *Antifriction bearing* section